

Poly(3-methylthiophene) electrochemical actuators showing increased strain and work per cycle at higher operating stresses

Binbin Xi ^a, Van-Tan Truong ^b, Philip Whitten ^a, Jie Ding ^a,
Geoffrey M. Spinks ^{a,*}, Gordon G. Wallace ^a

^a ARC Centre of Excellence in Electromaterials Science, Intelligent Polymer Research Institute, University of Wollongong,
Northfields Avenue, Wollongong, NSW 2522, Australia

^b Defence Science and Technology Organisation, Platforms Sciences Laboratory, Maritime Platforms Division,
P.O. Box 4331, Melbourne, VIC 3001, Australia

Received 25 September 2005; received in revised form 20 August 2006; accepted 23 August 2006
Available online 18 September 2006

Abstract

Conducting polymers, such as polythiophenes, are promising low voltage actuator materials. The performance of these materials has improved significantly in recent years. A remaining problem, however, is the significant decline in the actuation strain produced when the external stress is increased. Using a poly(3-methylthiophene) actuator in an ionic liquid electrolyte it is shown that the isotonic actuation actually increases with increasing applied stress. The work output per cycle consequently increases at higher stresses, which is very desirable for practical devices. Although theoretically predicted, these results are the first demonstration of the increased actuator performance at higher operating stresses. The actuation behaviour was found to be strongly dependent upon the operating electrolyte and explained by the shifts in the elastic modulus of the actuator material that occurred during operation.

© 2006 Elsevier Ltd. All rights reserved.

Keywords: Poly(3-methylthiophene) actuator; Ionic liquid; Isotonic tests

1. Introduction

Conducting polymers, such as polypyrrole, polyaniline and polythiophene are promising low voltage electrochemical actuator materials, whose performance has improved significantly in recent years. Polypyrrole (PPy) and polyaniline (PAn) as actuator materials have been studied in detail and typically exhibit ~5% strain and ~12 MPa stress [1–3], although much higher strains have recently been reported for PPy [4,5]. Recently polythiophene has attracted more attention due to claims of better oxidative stability both in air and moisture [6]. Kaneto et al. [7] reported a 2% actuation strain for poly(3-hexylthiophene) and poly(3-dodecylthiophene). A novel polythiophene based molecular actuator that exhibits actuation strains in the order of 20% due to a combined

mechanism of ion intercalation and accordion-like conformation rearrangements has been proposed by Anquetil et al. [8]. For conducting polymer actuators, the actuation performance is limited by IR drop along the actuator length due to poor electrical connection and polymer resistance. To reduce IR drop and thus enhance the actuation performance, a platinum wire has been incorporated into the wall of a hollow PPy fibre and this enables the PPy to generate the highest strain rate (13%/s) [9] and work per cycle (83 kJ/m³) [10] yet reported. Recent research work has also shown that the life cycle of conducting polymer actuators were greatly improved by operating the devices in ionic liquid (IL) electrolytes rather than in the conventional organic solvents such as propylene carbonate (PC) containing alkylammonium salts [11,12]. Up to 6000 cycles have been reported for PPy actuators with only a decrease of 20% actuation strain when IL was employed as electrolyte, while in PC based electrolyte, the actuation strain decreases by 75% after 3500 cycles [11].

* Corresponding author. Tel.: +61 2 4221 3010; fax: +61 2 4221 3114.
E-mail address: gspinks@uow.edu.au (G.M. Spinks).

An unresolved limitation of these materials, however, is the significant decrease in actuation strain produced when the operating stress increased [11,13–16]. Theoretical studies [15,17–20] have shown that the change in Young's modulus of the actuator material during operation is the key to understand the effect of load on actuation strain. In fact, it has been demonstrated previously that the actuation strain (ε_a) under isotonic conditions (ignoring the initial deformation when a stress σ is first applied) can be calculated from:

$$\varepsilon_a = \varepsilon_0 + \sigma \left(\frac{1}{Y'} - \frac{1}{Y} \right) \quad (1)$$

where ε_0 is the actuation strain of zero applied stress, and Y and Y' are the Young's moduli in the initial and final states, respectively. In all cases studied to date, the modulus shift during actuation has led to a decrease in ε_a as σ was increased. Separate tests showed that in such cases $Y' < Y$ and the measured strains could be accurately predicted using Eq. (1). It has not yet clearly understood why the modulus changes during redox cycling of conducting polymers, but it is presumably related to the addition/removal of charge from the chains and the change in the concentration of load-bearing chains due to the volume changes occurring. It has been shown experimentally that the modulus shift is strongly dependent upon the operating electrolyte, with less significant changes in modulus for polypyrrole occurring in ionic liquids ($\sim 8\%$) compared with alkylammonium salts in PC ($\sim 400\%$) [21].

In the present work, poly(3-methylthiophene) (P3MT) based actuators have been evaluated in ionic liquids and conventional electrolytes. A helical platinum wire was embedded in the polymer wall as an interconnect to provide better electrical connection and thus reduce IR drop along the tube. The actuation performances were investigated both in PC and IL ethylmethylimidazolium bistrifluoromethanesulfonimide (EMI·TFSI) with different applied loads. For the first time, an increase in actuation strain with higher applied load is reported. This behaviour leads to higher work per cycle as the applied load increases – an intriguing and desirable characteristic for actuator materials.

2. Experimental section

3-Methylthiophene (3MT), tetrabutylammonium hexafluorophosphate (TBA·PF₆) and propylene carbonate (PC) were obtained from Aldrich and used as received. Platinum (Pt) wires in 250 μm and 50 μm diameter were obtained from Goodfellow. The ionic liquid (IL) ethylmethylimidazolium bistrifluoromethanesulfonimide (EMI·TFSI) was synthesized in-house as reported previously [22].

The constant current required for polymerisation was applied using an EG and G Princeton Applied Research Model 363 potentiostat/galvanostat. The cyclic potential was applied by a Bioanalytical Systems Inc. CV-27. The actuation test was conducted on an Aurora Scientific Dual Mode Lever System 300B. All the experimental data were processed and recorded by MacLab/4e AD Instruments and computer.

The actuator was prepared following a similar procedure as described previously [9]. The P3MT actuator was grown galvanostatically for 15 h under a 0.1 mA/cm² current density. The polymerisation solution was the PC containing 3-methylthiophene monomer (0.2 M) and TBA·PF₆ (0.03 M). The temperature was controlled around 0–5 °C. A two electrode configuration was used. The working electrode was a 250 μm Pt wire core tightly wound by a 50 μm Pt wire as a helix and the auxiliary electrode was a stainless steel mesh. After polymerisation, the 250 μm Pt core was pulled out leaving a P3MT/PF₆ tube with the helical 50 μm Pt wire embedded in the polymer wall.

The actuation performance of P3MT/PF₆ actuators was tested on a Dual Mode Lever System 300B and shown schematically in Fig. 1. A triangular waveform varying from –1.0 V to 1.5 V at different potential scan rates from 2 mV/s to 50 mV/s was applied to the polymer using the CV-27. PC containing TBA·PF₆ (0.25 M) and IL (EMI·TFSI) were employed as electrolytes. The expansion/contraction of the samples was recorded during the test. Isotonic actuation tests were conducted at steadily increasing loads until the samples were broken.

Young's modulus of the P3MT/PF₆ sample was measured with a Dual Mode Lever System 300B while the sample was at the expanded or contracted states in electrolyte. Similar to the actuation test, the potential was scanned between –1.0 V and 1.5 V at a scan rate of 50 mV/s to drive the sample between the oxidized and reduced states. At both potential extreme (–1.0 V and +1.5 V) states, the potential was switched off, and then the sample was gradually stretched to a desirable strain, while a corresponding stress was recorded. The Young's modulus was determined from the linear section of the stress vs strain curve using linear regression.

3. Results and discussions

Figs. 2 and 3 show the cyclic voltammogram and actuation strain obtained for a P3MT tube doped with PF₆[–] (P3MT/PF₆) with platinum (Pt) helix as an interconnect. The actuation behaviour was studied in both PC based and IL electrolytes at different scan rates. As expected the current levels observed during cyclic voltammetry increased with increased scan rate. For both electrolytes, there was a significant current increase from 2 mV/s to 10 mV/s scan rate and another considerable increase occurs from 20 mV/s to 50 mV/s. Between 10 mV/s and 20 mV/s scan rate, the current increase was less. The current increase from low scan rate to high scan rate is approximately proportional to the difference of the scan rates. In PC, the recoverable actuation strain increased significantly from 0.3% to 0.8%, 1.5% and 2.1% when the potential scan rate was decreased from 50 mV/s to 20 mV/s, 10 mV/s and 2 mV/s, respectively. While in IL, only a slight increase of actuation strain from 0.4% to 0.5% was observed when the potential scan rate was decreased from 50 mV/s to 20 mV/s and 10 mV/s. When the potential scan rate was further decreased to 2 mV/s, the maximum recoverable strain was only 0.6%. These results indicated that the scanning rate

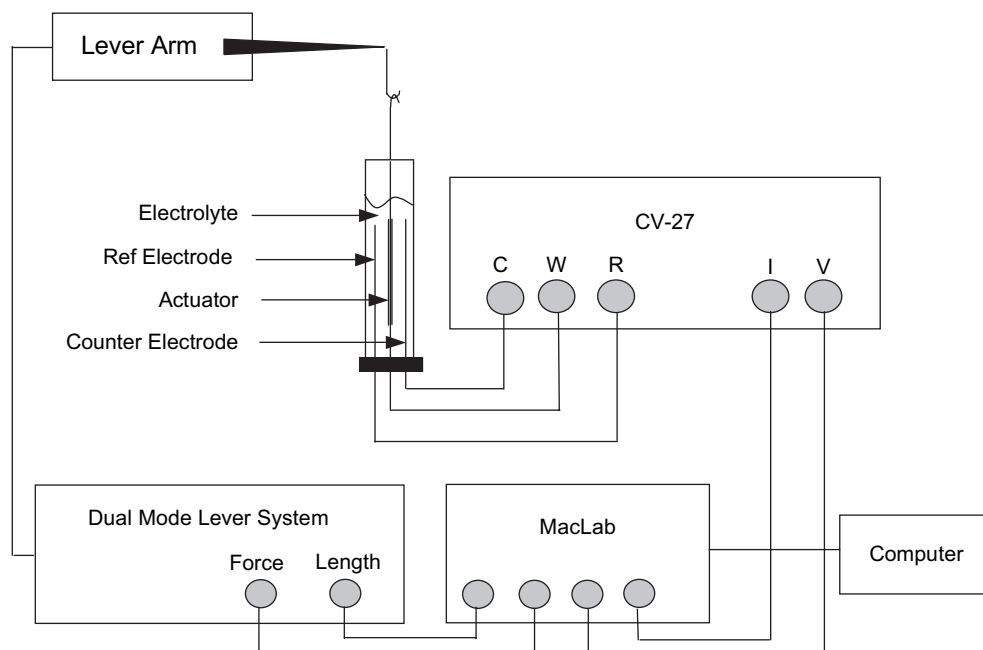

Fig. 1. Schematic of the experimental setup for actuation test.

had less effect on the actuation strain when the actuator was operated in IL.

Anion and/or cation exchange is the primary mechanism of conducting polymer electrochemical actuation [23–26]. In PC, P3MT/PF₆⁻ expanded at positive potentials and contracted at negative potentials. This behaviour indicates that the polymer releases PF₆⁻ during reduction (negative potential) and incorporates electrolyte anion (PF₆⁻) during oxidation (positive potential). In contrast, in IL the P3MT/PF₆⁻ expanded at negative potentials and contracted at positive potentials. This behaviour is similar to the results obtained previously with PPy actuators [11]. In IL, the polymer incorporated the ethylmethylimidazolium (EMI⁺) cations from electrolyte during reduction (negative potential) causing polymer expansion and released the cations during oxidation (positive potential) resulting in polymer contraction. The redox process may also involve the dopant anions moving in and out of the polymer but the cations from electrolyte dominate the actuation performance in IL. Thus, the polymer expansion caused by cation incorporation may be partly counteracted by the dopant anion released from the polymer. This mixed ion movements in IL may be the reason why the actuation strain in IL is lower than that in PC.

Solvent flux accompanying ion exchange also contributes to the actuation strain [13]. When the P3MT/PF₆⁻ actuator was operated in PC (0.25 M TBA·PF₆⁻) electrolyte, the solvent molecules may move into the polymer with solvated PF₆⁻ anions and contribute to the polymer expansion. Whilst in IL electrolyte, which is a pure electrolyte without any solvent, the actuation strain is merely derived from the ion exchange and there is no solvent contribution to the polymer expansion. This solvent contribution leads to higher actuation strain in PC than in IL. According to the EQCM study on

poly(3-hexylthiophene) by Brown et al. [27], under low scan rate 2 mV/s, the solvent transport during the redox process swells the polymer by 48% in thickness, which is a remarkable contribution compared to the total observed 63% swelling. As shown in Fig. 2, 2.1% strain can be achieved in PC electrolyte at 2 mV/s scan rate where solvent transport is likely to play an important role in the actuation performance. In contrast, at higher scan rates the actuation strain decreases to 0.3% when there is less time for solvent swelling.

The actuation strain resulting from anion or cation exchange between the polymer and the electrolyte not only depends on the concentration of anions or cations, but also relates to the diffusion rate of the ionic species. There are a number of factors that control diffusion, such as ion mobility, solution concentration, temperature and viscosity. The dominating anion PF₆⁻ in PC has better mobility than the dominating cation EMI⁺ in IL due to the smaller size and low solvent viscosity. Under low potential scan rates, there will be sufficient time for more ion exchange and solvent transport to occur. Consequently, as shown in Figs. 2 and 3, the actuation strains produced by the actuators are higher at low scan rates. In similar studies on polypyrrole, Skaarup and co-workers observed a decrease of strain from 1% to less than 0.2% when the potential scan rate was increased from 1 mV/s to 100 mV/s [28].

Interestingly, at faster scan rates (50 mV/s) the actuation strain obtained in IL (0.4%) was larger than when the PC electrolyte was used (0.3%). Under these circumstances, the contribution to actuation from solvent swelling is likely to be diminished. The higher strains observed in ionic liquid may then be related to the larger size of the intercalating ion (EMI⁺) compared with PF₆⁻ ion that is exchanged in the PC electrolyte.

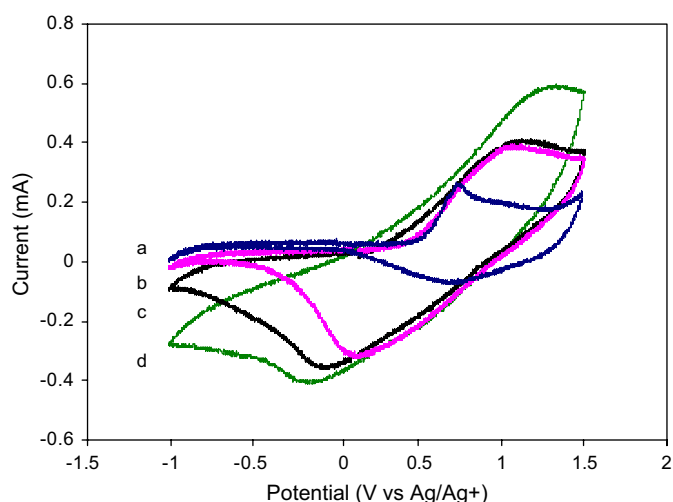
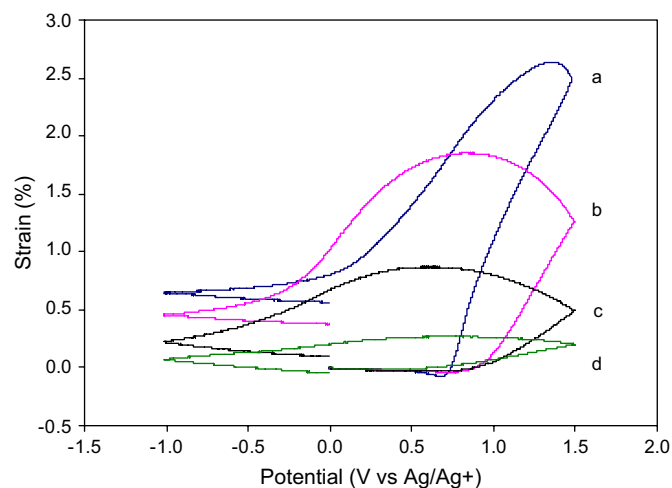

Fig. 2. Actuation strain and cyclic voltammetry (CV) of P3MT/PF₆ tube with a Pt helix in PC containing 0.25 M TBA·PF₆ at different scan rates: (a) 2 mV/s, (b) 10 mV/s, (c) 20 mV/s, and (d) 50 mV/s.

Fig. 4 illustrates the relationship between the applied stress and the actuation strain of the P3MT/PF₆/platinum helix when operated in PC and IL electrolytes. The actuators were evaluated during a contraction cycle (reported as a negative strain). The maximum stresses achieved in PC and IL were 2.5 MPa and 3.9 MPa, respectively. Although the Pt helix wire provides better electrical connection and thus reduce IR drop along the tube, it does not reinforce the strength of the materials (i.e., toughness), which is controlled by inherent imperfections formed in the material bulk during the polymerisation. It has also been previously reported that the incorporation of the Pt helix into the polymer tube decreases the tensile strength [9]. It is possible that the Pt–polymer interface is a source of high stress concentration leading to lower tensile strength. Higher actuator strength may be achieved by increasing the Pt–polymer adhesion. Using reinforcement fillers such as carbon nanotubes to replace the Pt helix in polymer is one of our research goals where carbon nanotubes can offer better electrical connection and also improve polymer tensile strength.

Similar to the previous results for PPy actuators [15,16], a linear decrease in actuation strain from -1.5% to -0.1%

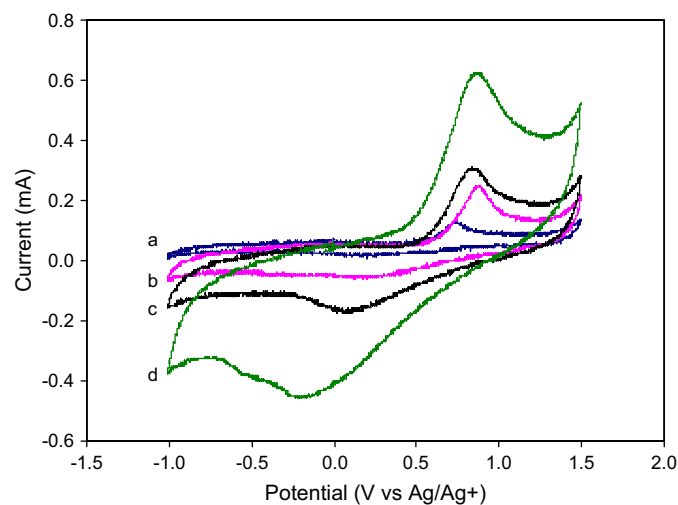
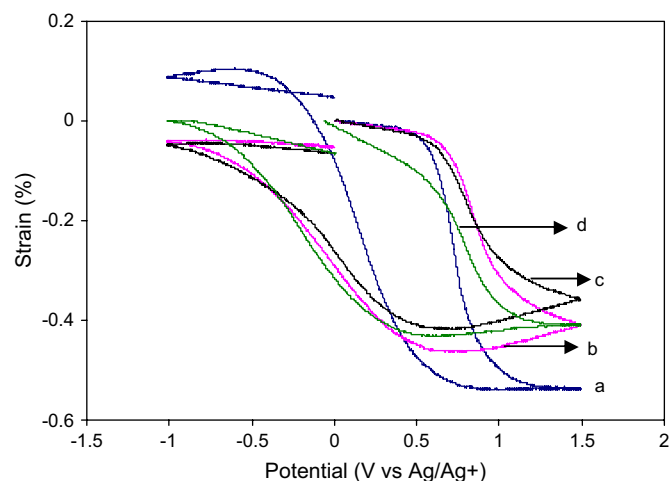

Fig. 3. Actuation strain and cyclic voltammetry (CV) of P3MT/PF₆ tube with a Pt helix in IL at different scan rates: (a) 2 mV/s, (b) 10 mV/s, (c) 20 mV/s, and (d) 50 mV/s.

occurred in PC with increasing applied stress and the sample eventually failed at 2.5 MPa. On the other hand, in IL the actuation strain slightly increased from -0.4% to -0.6% and the sample failed at 3.9 MPa. The test was repeated with another two samples in IL to confirm the increasing trend of the actuation strain with increasing applied loads. This is a promising result that can overcome the barrier limiting the application development due to strain decay with load. It has been reported by Lu et al. [12] and Ding et al. [11] that the use of IL as electrolyte can significantly improve the actuation performance in terms of lifetime cycles. The present work is the first report in which the actuation strain produced by a conducting polymer actuator increases under increasing load before failure.

The relationship between the actuation strain and the applied stress was first analyzed by Baughman [17] and more in detail by Spinks and Truong [19] and Tahhan et al. [20]. The total strain is the sum of the strain from electrochemical stimulation and the strain from external force and is predicted using Eq. (1). From Eq. (1) it can be seen that the Young's moduli shift between the final contracted and the initial

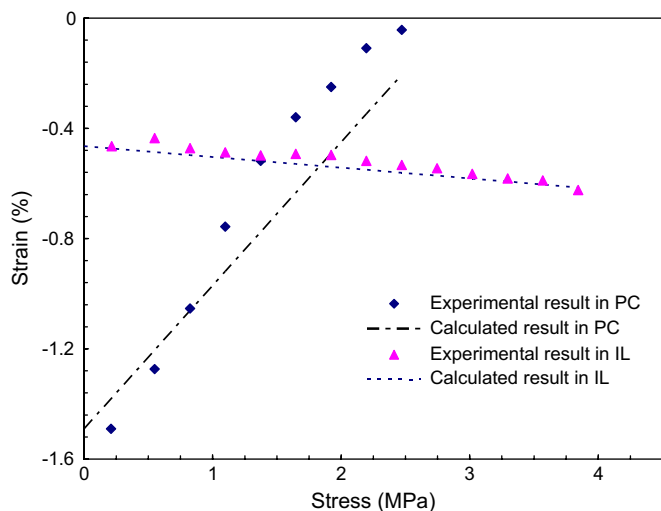

Fig. 4. Actuation strain of a P3MT/PF₆/Pt helix samples tested under isotonic conditions at different stress levels in both PC and IL electrolytes. Potential scanned between -1.0 V and 1.5 V (vs Ag/Ag⁺). Negative strains correspond to contraction. The calculated strains obtained from the Young's modulus model (Eq. (1)) are shown as dashed lines.

expanded states determines the slope of the actuation strain vs stress line. If $Y < Y'$, the actuation strain will increase with an increasing stress. On the other hand, if $Y > Y'$, the actuation strain will decrease with the increasing stress.

The Young's modulus of the P3MT/PF₆/Pt helix was measured in PC and IL when the sample was in the contracted or expanded states. Table 1 summarizes the Young's modulus measurement of the P3MT/PF₆/Pt helix samples in PC and IL.

In PC, the Young's modulus decreased significantly when the polymer was switched from the expanded to the contracted state. In IL, the Young's modulus slightly increased from the expanded to the contracted state. According to Eq. (1) and the Young's moduli in Table 1, the calculated actuation strains under increasing load were obtained and shown as dashed lines in Fig. 4. It can be seen that the calculated values are in good agreement with the experimental results. The slight shift between the experimental and calculated results in PC at higher loads is probably due to the polymer degradation when continuously cycled in PC electrolyte.

The difference in modulus shift observed in the two electrolytes is probably related to the osmotic processes occurring in PC but not in the IL. Doping of the polymer produces a high ion concentration within the polymer that is diluted by solvent ingress and driven by an osmotic pressure [13]. In IL electrolytes, however, there is no free solvent so osmotic processes are absent. The osmotic swelling in the PC no doubt

Electrolyte	Y expanded state (MPa)	Y' contracted state (MPa)
PC	109.4	69.6
IL	70.5	72.5

contributed to the higher strains, but also causes an increase in modulus in the expanded state since the chains are more extended and more difficult to further uncoil by external stress. In contrast, the smaller expansion that occurs in IL causes less chain expansion and there is a small decrease in modulus due to a small decrease in the concentration of load-bearing chains. The exact mechanism of modulus change in these polymers is the subject of on-going studies.

The work performed per expansion/contraction cycle is another important parameter to evaluate the performance of actuators [29]. The work per cycle, W , can be defined under isotonic conditions as:

$$W = f\Delta l_f \quad (\text{J}) \quad (2)$$

where Δl_f is taken as the displacement produced by one expansion/contraction cycle under a load f . On a volumetric basis the work per cycle W_v is given by:

$$W_v = \sigma|\varepsilon_a| \quad (\text{J/m}^3) \quad (3)$$

when an isotonic stress of σ is applied to the actuator. Fig. 5 shows the volumetric work per cycle performed by a P3MT/PF₆/Pt helix when operated in PC and IL. In PC, the work per cycle and applied stress curve shows a parabolic behaviour. In contrast, when an actuator is operated in IL, the work per cycle increases continuously with increasing applied stress. The maximum work per cycle achieved in IL (24 kJ/m^3) is about three times than that achieved in PC (8.7 kJ/m^3).

Combining Eqs. (1) and (2), the volumetric work per cycle can be calculated and is shown as dashed lines in Fig. 5. While the calculated work per cycle values in PC are an overestimation when the applied stress is larger than 1 MPa (due to cycle degradation), in IL the calculated work per cycle values are in excellent agreement with the measured values. Work per cycle available from the P3MT/PF₆ actuator operated in IL is limited only by the breaking strength of the material.

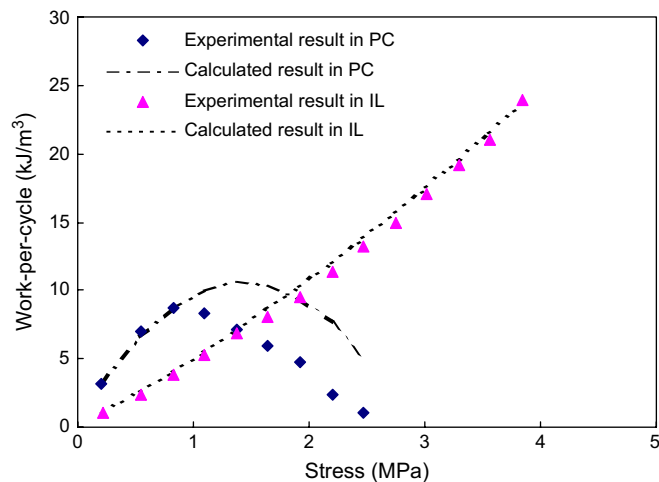

Fig. 5. Work per cycle for a P3MT/PF₆ tube with a Pt helix at different applied stress levels in PC and IL.

4. Conclusions

Practical applications of actuators will require operation under load. Previous studies of conducting polymer actuators indicate a decreased actuation strain when increasing loads were applied to the actuators. In this study, for the first time the actuator based on P3MT exhibits an increasing actuation strain and work per cycle with increasing applied stress. Based on this desirable behaviour, P3MT can be considered as a promising material for developing artificial muscles.

The actuation behaviour of the P3MT was found to be strongly dependent upon the electrolyte used. Since there is no solvent in the ionic liquid there was no contribution to actuation from osmotic effects. Consequently, the actuation strains were generally smaller in ionic liquid than in the conventional ions-in-solvent electrolyte. However, the actuation strain in the conventional electrolyte was very sensitive to the potential scan rate, probably because of the slowness of the osmotic solvent diffusion process. It was also observed that while anion exchange dominated in the conventional electrolyte, it was the cations that were exchanged when an ionic liquid was used. The reasons for the dominance of one ion over another are not yet well understood.

On the other hand, the performance of the actuators (strain and work per cycle) can be accurately predicted on the basis of linear-elastic mechanical behaviour when a shift in the actuator material's modulus is considered. Thus, the decrease in the modulus of P3MT during expansion (under reducing condition) produces a higher strain and work per cycle when operated in ionic liquid at higher isotonic stresses. In contrast, the P3MT operated in the conventional electrolyte showed an increase in modulus in the expanded (oxidized) state. The result was a linear decrease in strain with increasing stress and maximum work per cycle at an intermediate stress level. The reasons for the change in modulus with changing oxidation state of the polymer are the subject of on-going investigations.

References

- [1] Madden J, Vandesteeg N, Anquetil PA, Madden PG, Takshi A, Pytel RZ, et al. *IEEE Journal of Oceanic Engineering* 2004;29:706–29.
- [2] Otero T, Grande H-J. Electromechanical devices: artificial muscles based on conducting polymers. In: Skotheim T, Elsenbaumer R, Reynolds J, editors. *Handbook of conducting polymers*. New York: Marcel Dekker Inc; 1998.
- [3] Smela E. *Advanced Materials* 2003;15(6):481–94.
- [4] Bay L, West K, Sommer-Larsen P, Skaarup S, Benslimane M. *Advanced Materials* 2003;15(4):310–3.
- [5] Hara S, Zama T, Takashima W, Kaneto K. *Journal of Materials Chemistry* 2004;14(10 May 21):1516–7.
- [6] McCullough RD, Ewbank PC. *Handbook of conducting polymers*. New York: Marcel Dekker Inc; 1998. p. 225.
- [7] Fuchiwaki M, Takashima W, Kaneto K. *Molecular Crystals and Liquid Crystals* 2002;374:513–20.
- [8] Anquetil PA, Yu H, Madden JD, Swager TM, Hunter IW. Recent advances in thiophene based molecular actuators. In: *Proceeding of SPIE Smart Structures and Materials*; 2003.
- [9] Ding J, Liu L, Spinks GM, Zhou D, Wallace GG. *Synthetic Metals* 2003; 138:391–8.
- [10] Spinks GM, Zhou D, Liu L, Wallace GG. *Smart Materials and Structures* 2003;12(3):468–72.
- [11] Ding J, Zhou D, Spinks GM, Wallace GG, Forsyth S, Forsyth M, et al. *Chemistry of Materials* 2003;15(12):2392–8.
- [12] Lu W, Fadeev AG, Qi B, Smela E, Mattes BR, Ding J, et al. *Science* 2002;297(5583):983–7.
- [13] Bay L, Jacobsen T, Skaarup S, West K. *Journal of Physical Chemistry B* 2001;105:8492–7.
- [14] Sonoda Y, Takashima W, Kaneto K. *Synthetic Metals* 2001;119(1–3): 267–8.
- [15] Spinks GM, Liu L, Zhou D, Wallace GG. *Advanced Functional Materials* 2002;12(6, 7):437–40.
- [16] Spinks GM, Xi B, Zhou D, Truong VT, Wallace GG. *Synthetic Metals* 2004;140:273–80.
- [17] Baughman RH. *Synthetic Metals* 1996;78(3):339–53.
- [18] De Rossi D, Della Santa A, Mazzoldi A. *Synthetic Metals* 1997;90:93.
- [19] Spinks GM, Truong V-T. *Sensors and Actuators A: Physical* 2005;119(2): 455–61.
- [20] Tahhan M, Truong V-T, Spinks GM, Wallace GG. *Smart Materials and Structures* 2003;12:626–32.
- [21] Spinks GM, Xi B, Truong V-T, Wallace GG. *Synthetic Metals* 2005;151: 85–91.
- [22] Bonhote P, Dias A, Papageorgiou N, Kalyanasundaram K, Gratzel M. *Inorganic Chemistry* 1996;35:1168–78.
- [23] Gandhi MR, Murray P, Spinks GM, Wallace GG. *Synthetic Metals* 1995; 73(3):247–56.
- [24] Otero TF, Grande H, Rodriguez J. *Journal of Physical Organic Chemistry* 1996;9(6):381–6.
- [25] Skaarup S, Bay L, Vidanapathirana K, Thybo S, Tofte P, West K. *Solid State Ionics* 2003;159(1, 2):143–7.
- [26] Vidanapathirana KP, Careem MA, Skaarup S, West K. *Solid State Ionics* 2002;154–155:331–5.
- [27] Brown MJ, Hillman AR, Martin SJ, Cernosekb RW, Bandeyb HL. *Journal of Materials Chemistry* 2000;10:115–26.
- [28] Skaarup S, Mogensen N, Bay L, West K. Polypyrrole actuators for tremor suppression. In: *Proceedings of SPIE Smart Structures and Materials*; 2003. p. 5051.
- [29] Della-Santa A, DeRossi D, Mazzoldi A. *Synthetic Metals* 1997;90(2): 93–100.